

75ohm High-Pass Filter controls UHF Ingress to Satellite DBS Tuner

In the combined-band feed-cable to the set-top box, the satellite DBS band is at 950 to 2150 MHz, while the terrestrial band is at 54 to 860MHz. The high pass filter is needed at the set-top box input, to prevent UHF channels from reaching and desensitizing the satellite DBS Tuner. In this case, we built and tested the filter for use with the MAX2116 single-chip satellite tuner IC.

Introduction

While satellite TV has a variety of programming, it often does not cover the local channels for suburban and many urban areas. Satellite customers are combining terrestrial TV signals to their satellite feed (See Figure 1). After all, it is much easier to route one cable into the house than two cables. The best option is for the end user to use a satellite/TV diplexer to combine signals. However, these units only have so much stop band rejection. Many users may be in areas of high terrestrial TV signal strength and/or they may be using high gain Yagi antenna's.

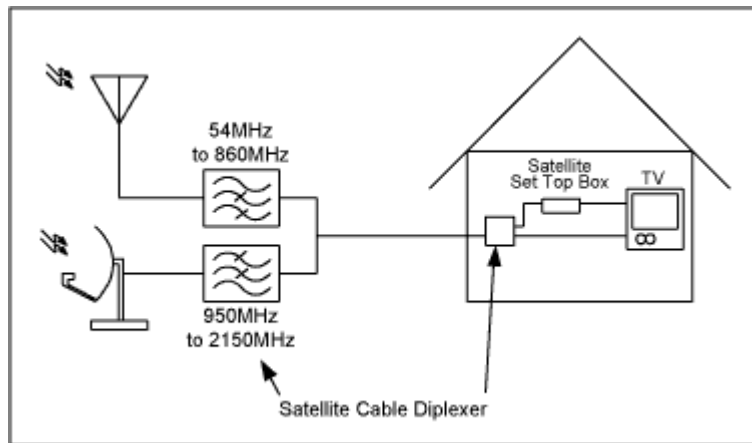

Figure 1. Satellite / Terrestrial Configuration

In the combined-band feed cable to the set-top box, the Satellite DBS band is at 950 to 2150 MHz, while the Terrestrial band is at 54 to 860MHz. The high pass filter is needed at the set-top box input, to prevent UHF channels from reaching and desensitizing the Satellite DBS Tuner. In this case, we built and tested the filter for use with the MAX2116 single-chip Satellite tuner IC.

Even when satellite and terrestrial TV signals are not combined, there may be other strong interferers. Satellite dishes have very high directivity but are still susceptible to blockers. Cellular telephone tower signals in the 825 to 895 MHz band, plus terrestrial broadcast TV stations can find their way onto the satellite feed line to the set-top box. These "blocking" signals can be coupled into the dish antenna via one of its side-lobes (ie. these are not perfectly directive), or they can get coupled simply due to close proximity and high power.

Filter Design

Given that we want to attenuate 54-860MHz by 20dB, while passing the Satellite L-band signals (950-2150MHz) with no more than 0.7dB insertion loss, we can calculate the filter mask. The band edge of the terrestrial signal (860MHz) is very close to the lower band edge of satellite (950MHz). The ratio from pass band to stop band is $1.1 = (950/860)$. Given this small ratio an elliptic filter will be chosen. Due to the very wide bandwidth satellite signal, a high pass filter will be chosen. It is difficult to design a band pass filter

with over an octave of pass band and low insertion loss. Due to cost and component tolerance issues, we will limit the elliptical filter to a four-section design.

The Low Noise Block (LNB) of a satellite tuner requires a DC voltage-feed through an inductor. We will utilize this inductor in the first shunt section of the four section elliptical high pass filter.

Figure 2 shows the schematic for a four section elliptical UHF ingress filter. This circuit has been built and tested using the following components:

- 1.8pF +/- 0.1pF capacitor
- 2.2pF +/- 0.1pF capacitor
- 18pF +/- 0.1pF capacitor
- 22pF 5% capacitor
- 10nH +/- 2% MuRata High-Q inductor (LQW1608A10NG00) Q=100 @1500MHz
- 22nH +/- 2% MuRata High-Q inductor (LQW1608A22NG00) Q=105 @1500MHz

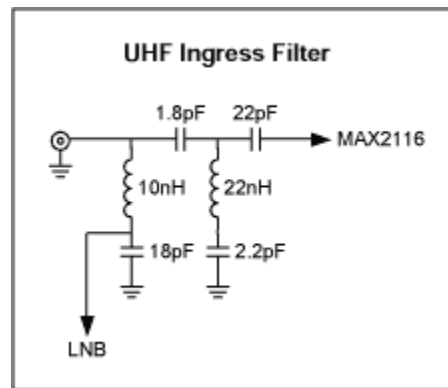

Figure 2. UHF Ingress Filter Schematic

There are many trade-offs in filter design. The goal is to achieve 20dB stop band attenuation with approximately 0.7dB nominal in-band insertion loss and 0.5dB ripple. Figures 3-6 show the actual measured return loss of the filter. These measurements have been made using a characteristic impedance, $Z_0 = 75\Omega$.

Figure 3 shows the s-parameter (S21) response of the filter. This was measured using a network analyzer on the circuit of Figure 2. The overall shape of the stop band looks very good. Even with an elliptical filter, the attenuation of the stop-band does not reach the full 20dB until 650MHz.

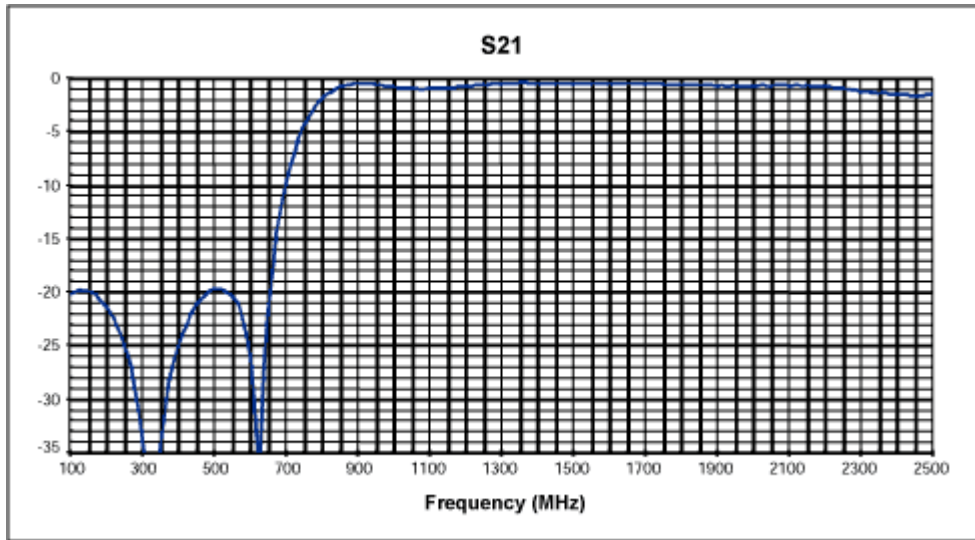

Figure 3 Filter S-Parameter measurement (S21)

Figure 4 shows the zoomed-in view of the pass band. The nominal loss is about 0.7dB with about 0.3dB ripple. It is good to minimize the in-band insertion loss. Each dB of loss will add to the noise figure if the satellite receiver.

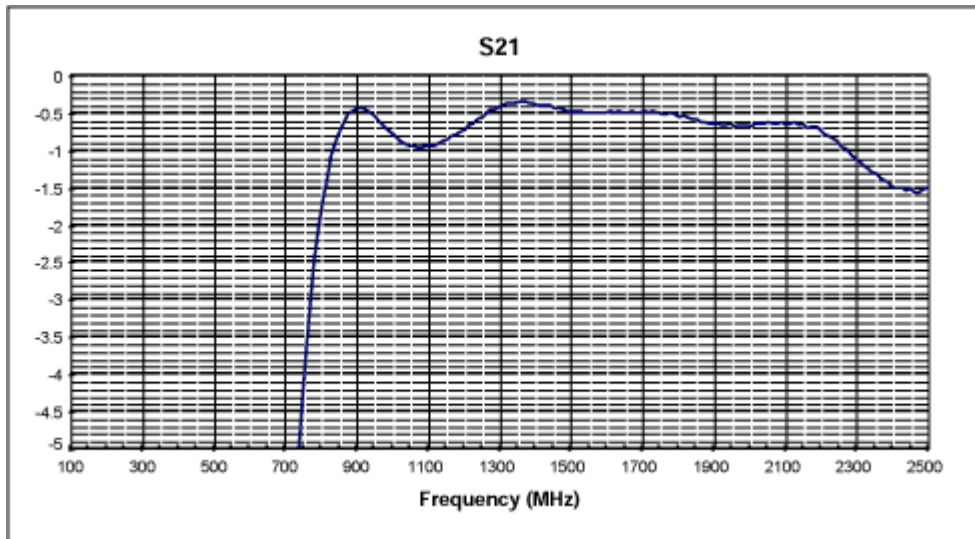

Figure 4. Zoomed in view of s-parameter (S21)

Figure 5 shows the input return loss for the filter (S11). The return loss is well within the DVB-S specification of 8dB.

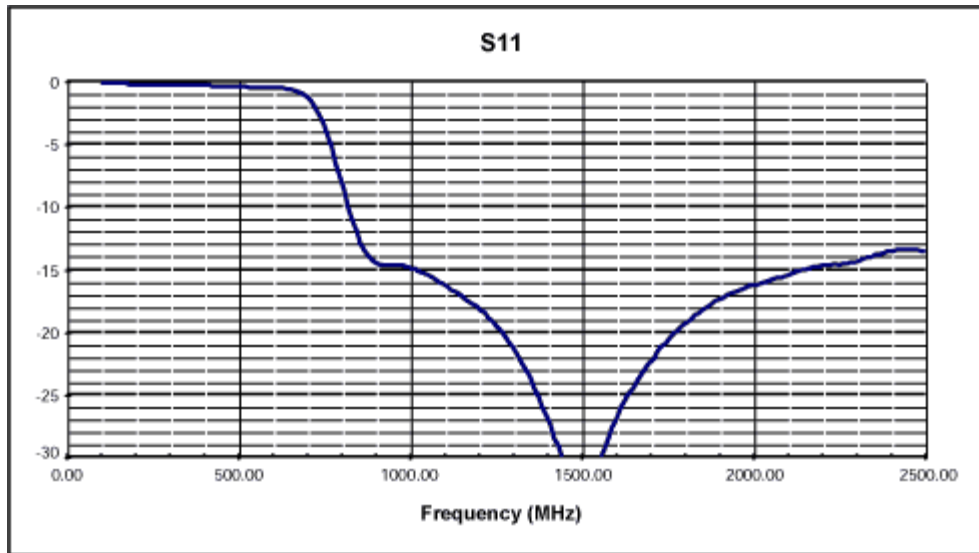

Figure 5 Input Return Loss

Figure 6 is the output return loss (S22). It shows a very good match to a 75Ω system.

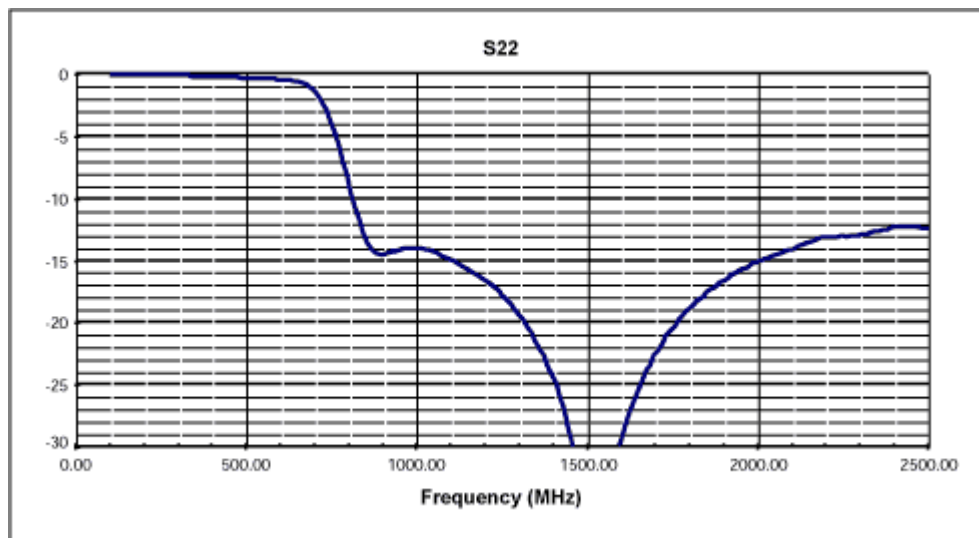

Figure 6 Output Return Loss

Summary

A filter for UHF ingress has been designed, built and measured to deliver 0.7dB \pm 0.3dB in-band loss from 950MHz to 2150MHz. The stop-band attenuation is >20dB from 54MHz to 650MHz. The filter shows good in-band return loss in a 75Ω environment.

MORE INFORMATION

MAX2116: [QuickView](#)

-- [Full \(PDF\) Data Sheet \(320k\)](#)

MAX2118: [QuickView](#)

-- [Full \(PDF\) Data Sheet \(320k\)](#)